

## DISC SUSPENSION PORCELAIN INSULATORS (ANSI)

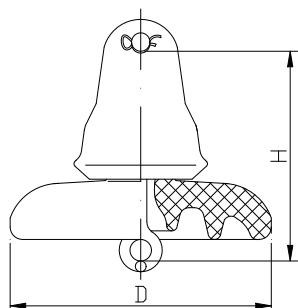

FIG. 1

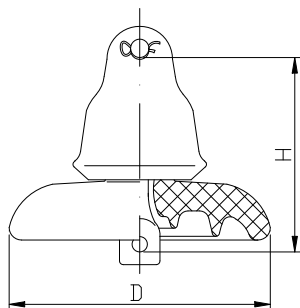

FIG.2

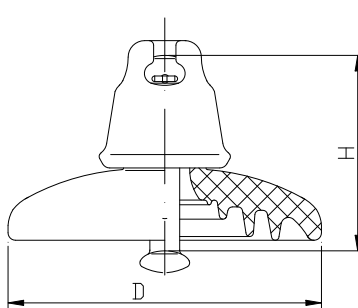

FIG.3

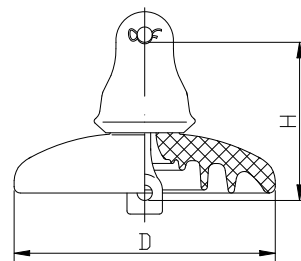

FIG.4

Cat. No.		0101044	0101087	0101067-1	0101087-2	0101111
Class		52-1	52-2	52-3	52-4	52-5
Fig. No.		1	2	3	4	3
Unit Spacing (H)-mm		140	146	146	146	146
Nominal Diameter (D)-mm		160	200	255	255	255
Leakage Distance-mm		178	210	292	292	279
Dry Arcing Distance-mm		114	154	197	197	197
Combined E & M Strength-KN		44	67	67	67	111
Tension Proof Test load-KN		22	33.5	33.5	33.5	55.5
Mechanical Impact Strength-N.m		5.0	5.5	6	6	7
Time Load Test Value-KN		26	40	44.5	44.5	67
Power Frequency Flashover	Wet-KV	30	35	50	50	50
	Dry-KV	60	65	80	80	80
Critical Impulse Flashover Voltage	Positive-KV	100	115	125	125	125
	Negative-KV	100	115	130	130	130
Low Frequency Puncture Voltage-KV		80	90	110	110	110
Radio Interference Voltage	Test Voltage to Ground-KV	7.5	7.5	10	10	10
	Max. RIV at 1MHz-uV	50	50	50	50	50
Weight-kg		2.5	3.6	4.6	4.9	5.6

## DISC SUSPENSION PORCELAIN INSULATORS

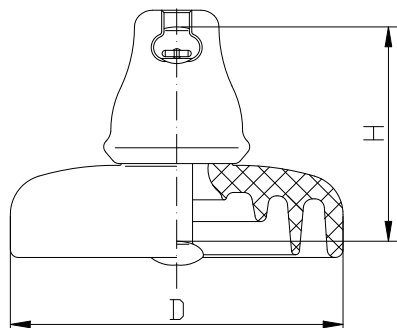

FIG.1

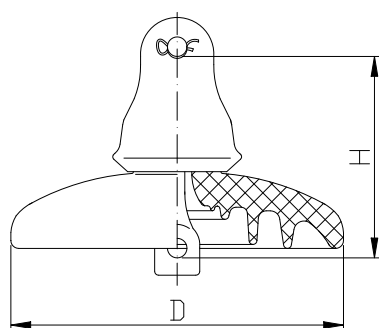

FIG.2

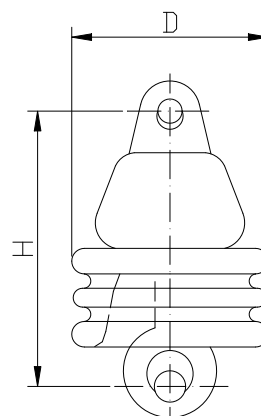

FIG.3

Cat. No.		0101111-1	0101160	0101160-1	0101044-1
Class		52-6	52-8	52-10	52-9-A
Fig.No.		2	1	2	3
Unit Spacing (H)-mm		146	146	146	159
Nominal Diameter (D)-mm		255	255	255	108
Leakage Distance-mm		279	279	279	171
Dry Arcing Distance-mm		197	197	197	--
Combined E & M Strength-KN		111	160	160	44
Tension Proof Test load-KN		55.5	80	80	22
Mechanical Impact Strength-N.m		7.0	10	10	5.0
Time Load Test Value-KN		67	96	96	26
Power Frequency Flashover	Wet-KV	50	50	50	30
	Dry-KV	80	80	80	60
Critical Impulse Flashover Voltage	Positive-KV	125	125	125	90
	Negative-KV	130	130	130	100
Low Frequency Puncture Voltage-KV		110	110	110	80
Radio Interference Voltage	Test Voltage to Ground-KV	10	10	10	7.5
	Max. RIV at 1MHz-uV	50	50	50	50
Weight-kg		5.6	6.7	6.7	2.5

## DISC SUSPENSION PORCELAIN INSULATORS

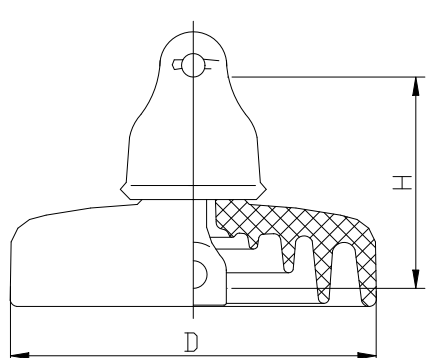

FIG.1

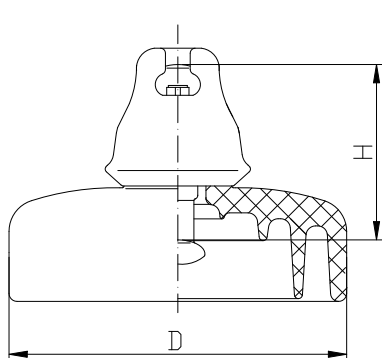

FIG.2

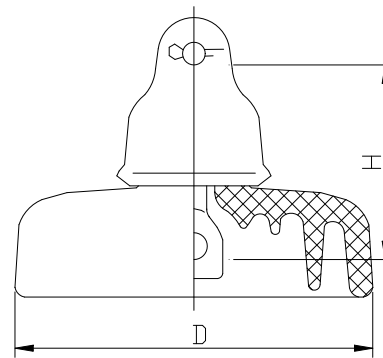
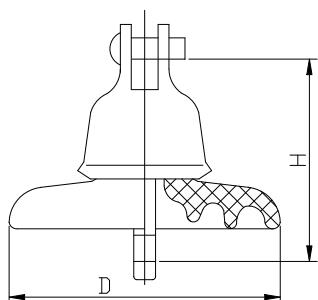

FIG.3

Cat. No.		0101089	0101089-1	0101133	0101133-1	0101160	0101160-1
Class		52-3	52-4	52-5	52-6	52-8	52-10
Fig. No.		2	1	2	3	2	3
Unit Spacing (H)-mm		146	146	146	146	159	165
Nominal Diameter (D)-mm		255	255	255	255	255	255
Leakage Distance-mm		432	432	432	432	432	432
Dry Arcing Distance-mm		229	203	216	203	216	203
Combined E & M Strength-KN		89	89	133	133	160	160
Tension Proof Test load-KN		44.5	44.5	67	67	80	80
Mechanical Impact Strength-N.m		10	10	10	10	10	10
Time Load Test Value-KN		53	53	80	80	107	107
Power Frequency Flashover	Wet-KV	50	50	50	50	50	50
	Dry-KV	80	80	80	80	80	80
Critical Impulse Flashover Voltage	Positive-KV	125	125	125	125	125	125
	Negative-KV	130	130	130	130	130	130
Low Frequency Puncture Voltage-KV		120	120	120	120	120	120
Radio Interference Voltage	Test Voltage to Ground-KV	10	10	10	10	10	10
	Max. RIV at 1MHz-uV	50	50	50	50	50	50
Weight-kg		6.2	6.2	7.3	6.8	8.6	9.1

## NORMAL TYPE DISC SUSPENSION PORCELAIN INSULATORS (IEC)



**FIG.1**

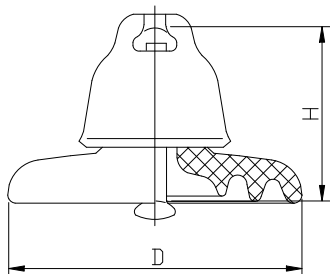

**FIG.2**

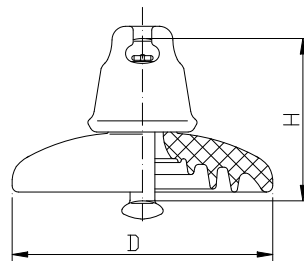
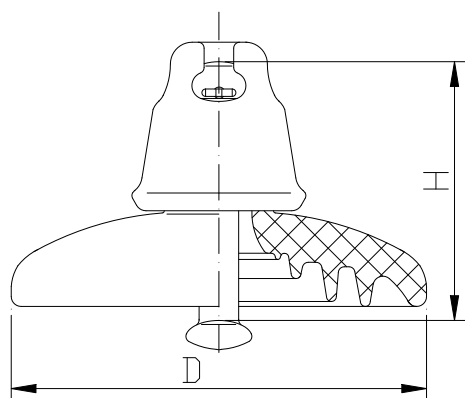

**FIG.3**

**FIG.4**

Cat No.		0104040C	0104040B	0104070BL	0104070C	0104070BS	0104070-09
Class		U40C	U40B	U70BL	U70C	U70BS	U70BL
Fig. No.		1	2	3	4	3	3
Unit Spacing (H)-mm		140	110	146	146	127	146
Nominal Diameter (D)-mm		190	175	255	255	255	255
Coupling size		--	11	16A/B	16C	16A	16A/16B
Nominal Creepage Distance-mm		200	185	295	295	295	320
Rated E & M Failing Load-KN		40	40	70	70	70	70
Routine Tensile Load-KN		20	20	35	35	35	35
Impact Strength-N.m		5	5	6	6	6	6
Power Frequency Withstand	Wet-KV	30	30	40	40	40	40
	Dry-KV	55	55	70	70	70	70
Dry Lighting Impulse Withstand Voltage-KV		75	75	110	110	110	110
Power Frequency Puncture Voltage-KV		90	90	110	110	110	110
Radio Interference Voltage	Test Voltage to Ground-KV	7.5	7.5	10	10	10	10
	Max. RIV at 1MHz-uV	50	50	50	50	50	50
Weight-kg		2.5	2.4	4.8	4.7	4.7	5.0

## NORMAL TYPE DISC SUSPENSION PORCELAIN INSULATORS



**FIG.1**

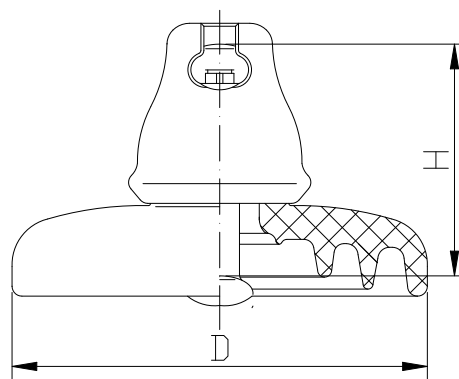

**FIG.2**

Cat. No.	0104080BL	0104080BS	0104100BL	0104100BL-1	0104120B
Class	U80BL	U80BS	U100BL	U100BL	U120B
Fig. No.	1	1	2	2	2
Unit Spacing (H) - mm	146	140	146	146	146
Nominal Diameter (D) -mm	255	255	255	280	255
Coupling size	16A/B	16A/B	16A/B	16A/B	16A/B
Nominal Creepage Distance-mm	295	295	295	340	320
Rated E & M Failing Load-KN	80	80	100	100	120
Routine Tensile Load-KN	40	40	50	50	60
Impact Strength-N.m	6	6	7	7	7
Power Frequency Withstand	Wet-KV	40	40	40	40
	Dry-KV	70	70	70	70
Dry Lighting Impulse Withstand Voltage-KV	110	110	110	110	110
Power Frequency Puncture Voltage-KV	110	110	110	110	110
Radio Interference Voltage	Test Voltage to Ground-KV	10	10	10	10
	Max. RIV at 1MHz-uV	50	50	50	50
Weight-kg	5.4	5.2	5.7	6.2	5.8

## NORMAL TYPE DISC SUSPENSION PORCELAIN INSULATORS

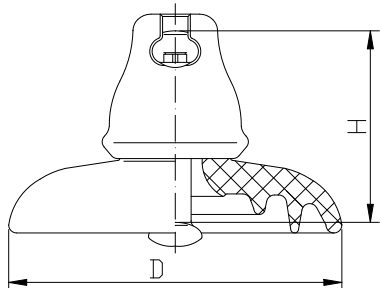

**FIG.1**

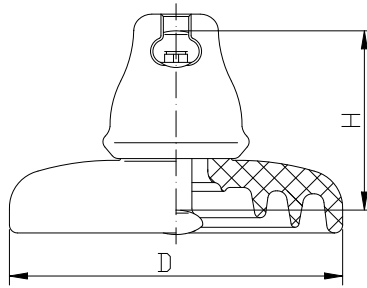

**FIG.2**

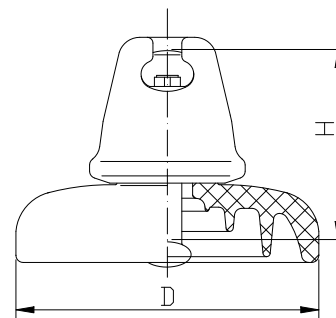

**FIG.3**

Cat. No.	0104160BL	0104160BS	0104160BS-1	0104160BL-1	0104160BL-2
Class	U160BL	U160BS	U160BS	U160BL	U160BL
Fig. No.	1	1	1	2	3
Unit Spacing (H) -mm	255	255	280	300	255
Coupling size	20	20	20	20	20
Nominal Creepage Distance-mm	305	320	315	400	390
Rated E & M Failing Load-KN	160	160	160	160	160
Routine Tensile Load-KN	80	80	80	80	80
Impact Strength -N.m	10	10	10	10	10
Power Frequency Withstand	Wet-KV	40	40	45	45
	Dry-KV	70	70	75	75
Dry Lighting Impulse Withstand Voltage-KV	110	110	110	110	110
Power Frequency Puncture Voltage - KV	110	110	110	110	110
Radio Interference Voltage	Test Voltage to Ground-KV	10	10	10	10
	Max. RIV at 1MHz-uV	50	50	50	50
Weight -kg	7.0	7.2	7.6	8.3	7.6

## FOG TYPE DISC SUSPENSION PORCELAIN INSULATORS

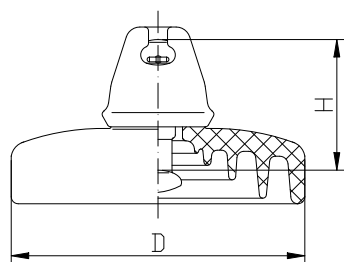

**FIG. 1**

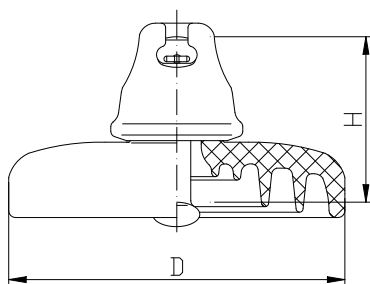

**FIG.2**

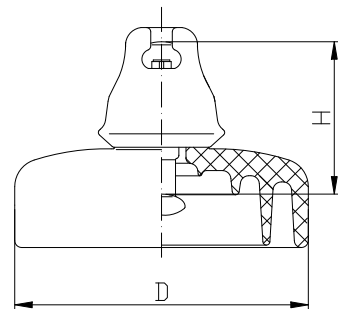

**FIG.3**

Cat. No.		0104070BLP	0104070BLP-1	0104080BLP	0104100BLP	0104100BLP-1
Class		U70BLP	U70BLP	U80BLP	U100BLP	U100BLP
Fig. No.		1	2	1	3	3
Unit Spacing (H)-mm		146	146	146	146	146
Nominal Diameter (D)-mm		255	280	255	255	255
Coupling size		16A/B	16A/B	16A/B	16A	16A
Nominal Creepage Distance-mm		432	440	432	432	440
Rated E&M Failing Load-KN		70	70	80	100	100
Routine Tensile Load -KN		35	35	40	50	50
Impact Strength-N.m		6	6	6	7	7
Power Frequency Withstand	Wet-KV	42	42	42	42	45
	Dry-KV	80	80	80	80	80
Dry Lighting Impulse Withstand Voltage-KV		120	120	120	120	120
Power Frequency Puncture Voltage-KV		120	120	120	120	120
Radio Interference Voltage	Test Voltage to Ground-KV	10	10	10	10	10
	Max. RIV at 1MHz-uV	50	50	50	50	50
Weight-kg		6.5	6.7	6.6	7.9	7.6

## FOG TYPE DISC SUSPENSION PORCELAIN INSULATORS

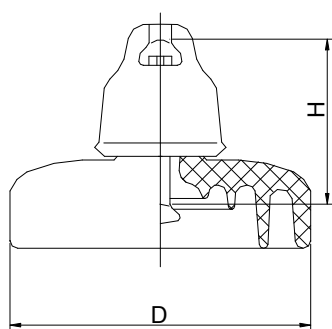

**FIG.1**

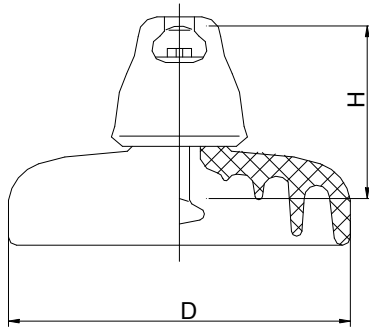

**FIG.2**

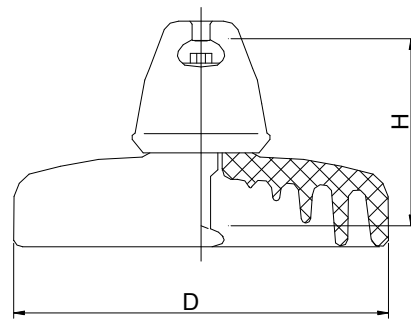
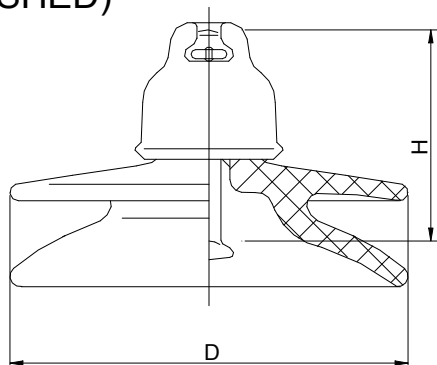

**FIG.3**

Cat. No.	0104120BP	0104120BP-1	0104160BP	0104160BSP	0104160BLP
Class	U120BP	U120BP	U160BO	U160BSP	U160BLP
Fig. No.	1	1	2	2	3
Unit Spacing (H)-mm	146	146	155	146	170
Nominal Diameter (D)-mm	255	280	300	330	320
Coupling size	16A	16A	20	20	20
Nominal Creepage Distance-mm	432	440	450	440	525
Rated E&M Failing Load-KN	120	120	160	160	160
Routine Tensile Load -KN	60	60	80	80	80
Impact Strength-N.m	10	10	10	10	10
Power Frequency Withstand	Wet-KV	42	42	45	45
	Dry-KV	80	80	80	90
Dry Lighting Impulse Withstand Voltage-KV	120	120	120	120	135
Power Frequency Puncture Voltage-KV	120	120	130	130	130
Radio Interference Voltage	Test Voltage to Ground-KV	10	10	10	10
	Max. RIV at 1MHz-uV	50	50	50	50
Weight-kg	7.9	7.6	10.3	10.4	11.5



## ANTI-POLLUTION SUSPENSION PORCELAIN INSULATORS (DOUBLE-SHED)



**FIG.1**

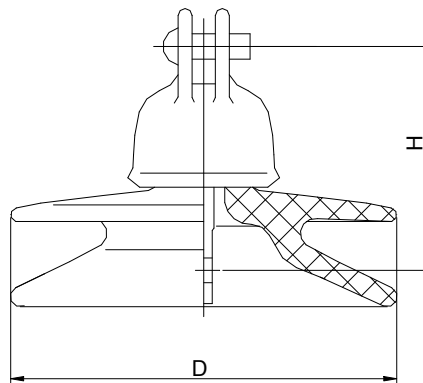

**FIG.2**

Cat. No.	010470BPW	010470CW	010470BPW-1	0104100BPW	0104120BPW	0104160BPW
Class	U70BP	U70C	U70BP	U100BP	U120BP	U160BP
Fig. No.	1	2	1	1	1	1
Unit Spacing (H)-mm	146	146	146	160	146	155
Nominal Diameter (D)-mm	255	255	280	280	280	300
Coupling size	16	16C	16	16A/B	16A	20
Nominal Creepage Distance-mm	400	400	450	450	450	450
Rated E&M Failing Load-KN	70	70	70	100	120	160
Routine Tensile Load -KN	35	35	35	50	60	80
Power Frequency Withstand	Wet-KV	42	42	45	45	45
	Dry-KV	80	80	80	80	80
Dry Lighting Impulse Withstand Voltage-KV	120	120	120	120	120	120
Power Frequency Puncture Voltage-KV	120	120	120	120	120	120
Radio Interference Voltage	Test Voltage to Ground-KV	10	10	10	10	10
	Max. RIV at 1MHz-uV	50	50	50	50	50
Weight-kg	5.9	5.9	7.0	8.4	8.1	9.4

## AERODYNAMIC SUSPENSION PORCELAIN INSULATOR

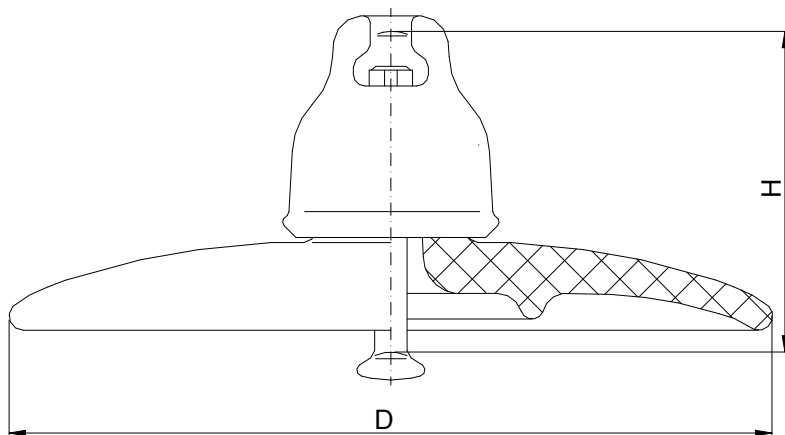

Cat. No.		0104070M	0104080M	0104100M	0104120M	0104160M
Unit Spacing (H)-mm		146	146	146	146	155
Nominal Diameter (D)-mm		350	330	360	360	360
Coupling size		16	16	16	16	20
Nominal Creepage Distance-mm		300	305	300	300	300
Rated E&M Failing Load-KN		70	80	100	120	160
Routine Tensile Load -KN		35	40	50	60	80
Power Frequency Withstand	Wet-KV	40	40	40	40	40
	Dry-KV	70	70	70	70	70
Dry Lighting Impulse Withstand Voltage-KV		105	95	105	105	105
Power Frequency Puncture Voltage-KV		120	120	120	120	120
Radio Interference Voltage	Test Voltage to Ground-KV	10	10	10	10	10
	Max. RIV at 1MHz-uV	50	50	50	50	50
Weight-kg		6.0	5.7	7.2	7.2	8.1

## NORMAL TYPE DISC SUSPENSION PORCELAIN INSULATORS

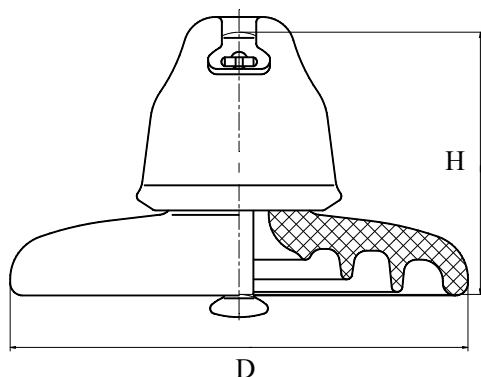

Fig 1

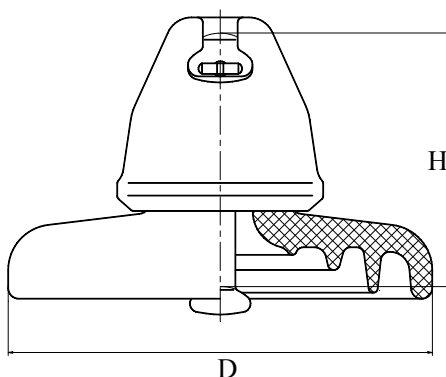

Fig 2

Cat. No.		0104210-01	0104210-02	0104210-03
Class		U210B	U210B	U210B
Fig. No.		1/2	2	1
Unit Spacing (H)-mm		170	170	170
Nominal Diameter (D)-mm		280	300	300
Coupling size		20/24	20/24	20
Nominal Creepage Distance-mm		335/380	370/400	330
Rated E&M Failing Load-KN		210	210	210
Routine Tensile Load -KN		105	105	105
Impact Strength-N.m		10	10	10
Power Frequency Withstand	Wet-KV	40/42	42	40
	Dry-KV	70/75	75	70
Dry Lighting Impulse Withstand Voltage-KV		105	110	105
Power Frequency Puncture Voltage-KV		120	120	120
Radio Interference Voltage	Test Voltage to Ground-KV	10	10	10
	Max. RIV at 1MHz-uV	50	50	50
Weight-kg		9.5/10.8	11	10.6

## NORMAL TYPE DISC SUSPENSION PORCELAIN INSULATORS

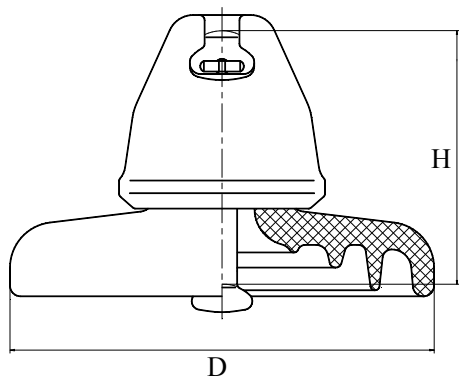

Fig 1

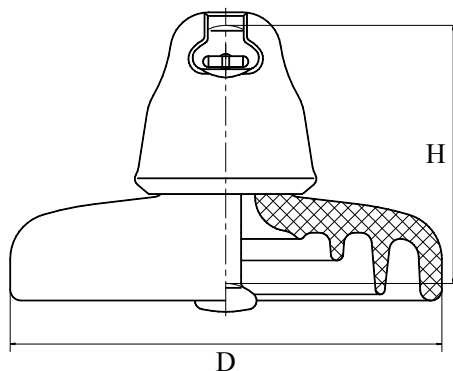

Fig 2

Cat. No.	0104240	0104300	0104400	0104530
Class	U240B	U300B	U400B	U530B
Fig. No.	1	1	2	2
Unit Spacing (H)-mm	170	195	205	240
Nominal Diameter (D)-mm	280	320	360	380
Coupling size	24	24	28	32
Nominal Creepage Distance-mm	405	370	525	600/700
Rated E&M Failing Load-KN	240	300	400	530
Routine Tensile Load -KN	120	150	200	265
Impact Strength-N.m	10	10	10	10
Power Frequency Withstand	Wet-KV	45	45	50
	Dry-KV	75	75	90
Dry Lighting Impulse Withstand Voltage-KV	110	110	140	140
Power Frequency Puncture Voltage-KV	120	120	130	140
Radio Interference Voltage	Test Voltage to Ground-KV	10	10	10
	Max. RIV at 1MHz-uV	50	50	50
Weight-kg	11.4	13.5	20.4	23.5/27

## ANTI-POLLUTION DISC SUSPENSION PORCELAIN INSULATORS

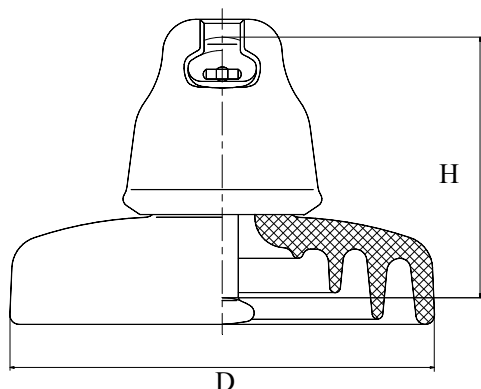

Fig 1

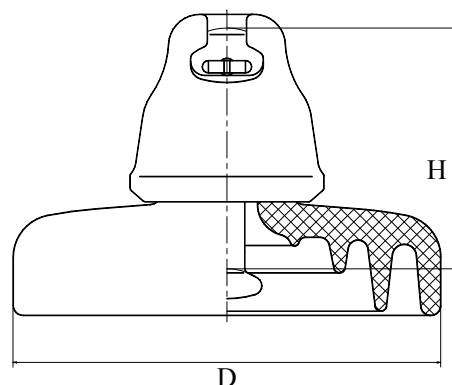

Fig 2

Cat. No.	0104210-XHP-01	0104210-XHP-02	0104240-XHP	0104300-XHP-01	0104300-XHP-02	
Class	U210B	U210BP	U240BP	U300B	U300BP	
Fig. No.	1	2	1	1	2	
Unit Spacing (H)-mm	170	170	170	195	195	
Nominal Diameter (D)-mm	300	330	320	320	380	
Coupling size	20/24	20	24	24	24	
Nominal Creepage Distance-mm	450/470	550	550	485/505	690	
Rated E&M Failing Load-KN	210	210	240	300	300	
Routine Tensile Load -KN	105	105	120	150	150	
Impact Strength-N.m	10	10	10	10	10	
Power Frequency Withstand	Wet-KV	45	55	55	45	60
	Dry-KV	80	90	90	80	100
Dry Lighting Impulse Withstand Voltage-KV	130	135	135	130	140	
Power Frequency Puncture Voltage-KV	130	130	130	130	140	
Radio Interference Voltage	Test Voltage to Ground-KV	10	10	10	10	10
	Max. RIV at 1MHz-uV	50	50	50	50	50
Weight-kg	12.5	14.6	15.5	14.6	21.4	